

APPROVAL SHEET

CUSTOMER	
MODEL NO	HDL-501 Rev. 1.02
CUSTOMER MODEL	
ISSUED DATE	2011. 11.28

SIGNATURE	DESIGN	CHECK	APPROVAL
HD LCD			
CUSTOMER			



Head Office / Factory

2F Samwon bldg , 391-30 Cheongcheon-dong, Bupyeong-gu, Incheon, Korea
<http://www.lcd1004.co.kr>

Record of revisions.

Tel. +82-32-518-1070 Fax.+82-32-518-1076

Rev. No	Date	Page	Description	Issued by
1.0	July.14.2011		1 st Description	

CONFIDENTIAL

Contents

1. GENERAL DESCRIPTION
2. FEATURES
3. BLOCK DIAGRAM
4. VB-501 Function and Layout
5. Control Board Dimensions
6. Electrical Specifications
7. LCD Panels Supported
8. OSD (On Screen Display)
9. Input and Output Connectors for LCD Interface
10. Applicable Graphic Mode

1. GENERAL DESCRIPTION

VB-501 is an advanced TFT LCD Monitor Control Board.

This design enables a full conventional CRT monitor replacement with a large size Active Matrix LCD module.

It is suitable for video resolution up to WSXGA+ @ 60Hz(DVI @60Hz) in all video modes the full display area of the module is used.

The design is implemented as a single printed circuit board.

As the VB-501 is designed to act as a full monitor interface besides the main functionality of an analog also various appealing On-Screen-Display Menu layouts are possible on customer's request.

It is VB-501 designed to support various TFT LCD under the WSXGA+ resolution by BIOS option, customer's line-up their monitors with their own identity with following options.

2. FEATURES

- State of the art high performance picture quality and low cost design
- Supports 1 CVBS input format)
- Supports Analog input format
- Supports HDMI input format
- Supports CVBS input / Out format
- Full CRT multi-sync monitor compatibility
- Multi-sync capability up to WSXGA+ resolution @ 60Hz,compatible standard
- DOS, VGA, SVGA, XGA,WSXGA+ VESA timing
- Expand DOS, VGA, SVGA, XGA and WSXGA+ to full screen display
- Up-to 720P HD signal input support.(HDMI)
- NTSC/PAL Video system support (CVBS)
- True color (16.2M) data processing and display driving
- Single control operated On-Screen-Display (hereafter "OSD") user interface
- Full control of all relevant display and interface parameters via OSD
- Multi language support
- VESA DDC 1/2B compliant
- Compatible with VESA DPMS power saving modes
- Low power consumption: operating 54W, power save 5W
- Small form factor: 148 X 95 mm
- +12VDC single power: 54 watts AC/DC power adapter recommended
- Operation temperature: 0 to 50℃
- Audio (2Channel input) support.(Built in A/D board)
- Power Lips Inverter Option.

3. BLOCK DIAGRAM

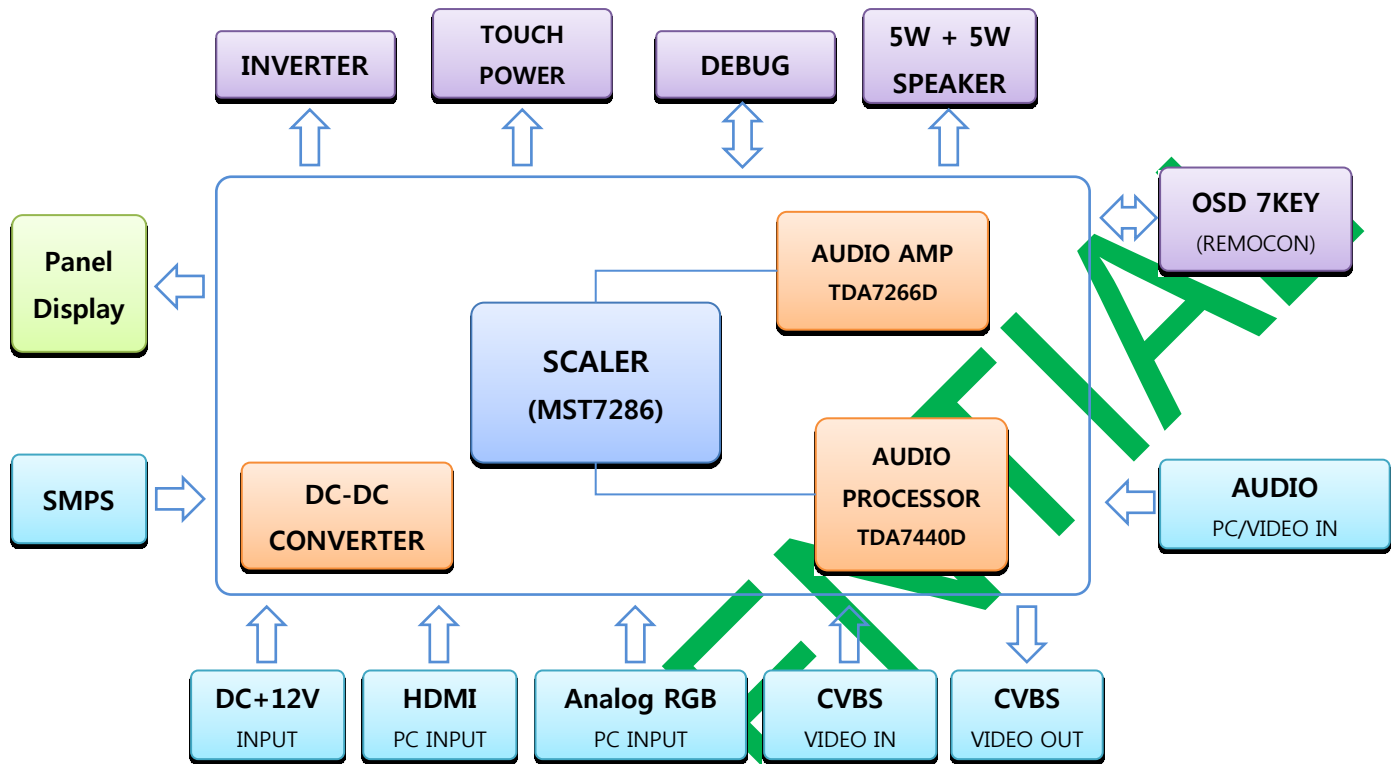

4. VB-501 FUNCTION and LAYOUT

4-1. Picture of lcd control board

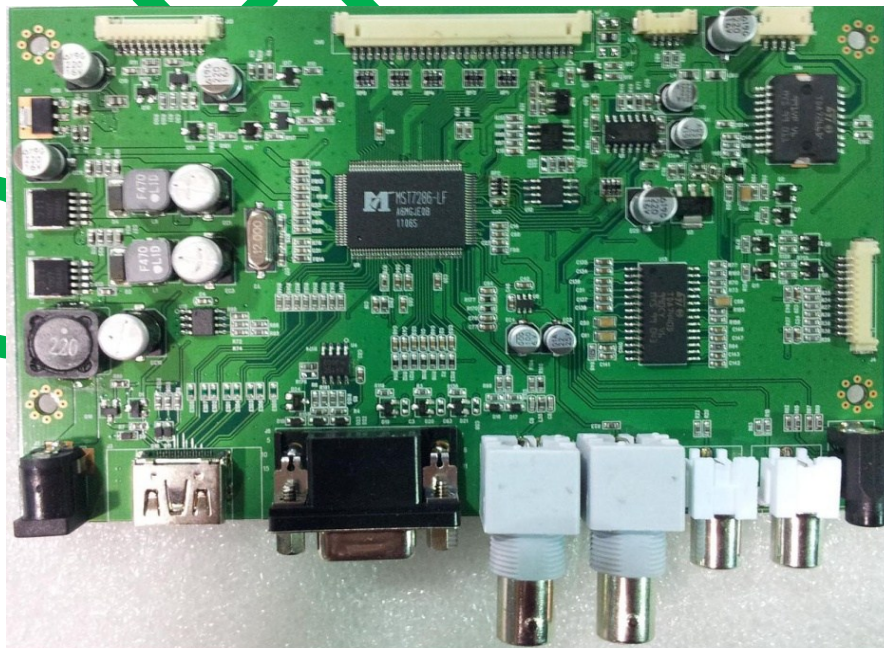

4-2. Interface function description

	Service	Maker	Part number	Description	Mating housing
CN9	LCD I/F(LVDS)	YEON HO	12507WR-30P	1.25mm, 30P, R/A	YEON HO / 12507HS-30
CN2	INVERTER I/F	YEON HO	SMAW200-06	2mm,06P	SMH200-06
J4	OSD I/F	YEON HO	12505WR-12	1.25mm,12P	12505HS-12
J5	RGB IN	P.D	PD526A-151100	15p R/A	Standard VGA cable(Male)
J3	HDMI IN	PRODUCER CO.,LTD			STANDARD HDMI CABLE
J2	DC IN	S.C	PD527A-2111	2.5Ø,DC-JACK	2.5pi, DC Adapter
J8/J7	CVBS1 IN	SUNG HO	SW-2584,S/W BNC	BNC	Standard BNC Cable
J11/J12	CVBS1 OUT	SUNG HO	SW-2584,S/W BNC	BNC	Standard BNC Cable
J10	CVBS Audio IN(LEFT)	B.S	BS-V13050(W)	3.5 Ø	RCA PHONE JACK
J9	CVBS Audio IN(RIGHT)	B.S	BS-V13050(R)	3.5 Ø	RCA PHONE JACK
J6	AUDIO IN	S.C	PJ325B-5P	3.5 Ø,5PIN R/A	PHONE JACK
CN3	SPEAKER OUT	YEON HO	20017WS-04	2mm,02P,S/T	20017HW-04
CN8	Debug Port	YEON HO	12505WR-04	1.25mm,04P	12505HS-04
CN4	TOUCH-POWER	YEON HO	SMAW200-03	2mm,03P	SMH200-03
CN5	DC-IN1	YEON HO	SMAW200-04	2mm,04P	SMH200-04

5. CONTROL BOARD DIMENSIONS

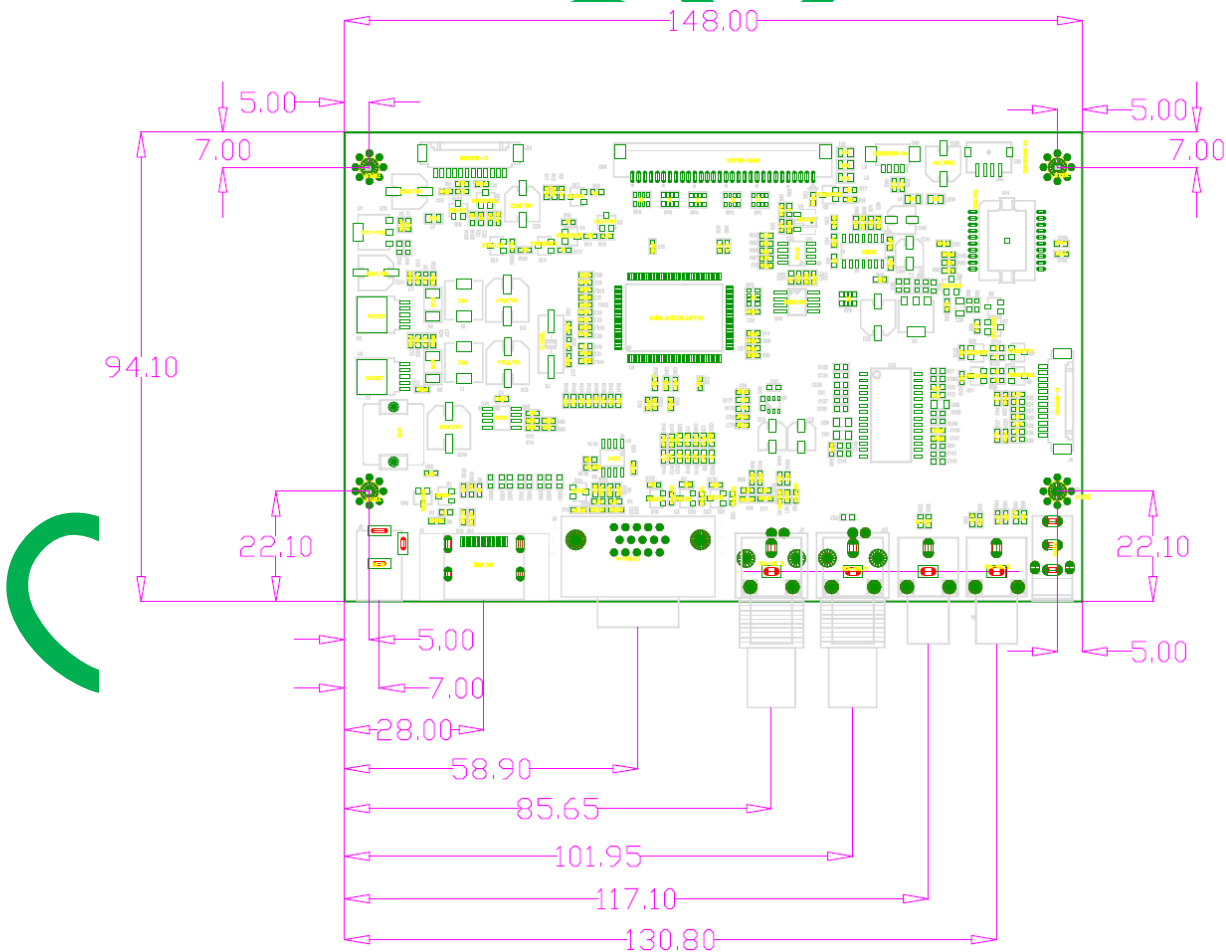

6. Electrical Specifications

6-1. Electrical Specification

Item	Symbol	Condition	MIN.	TYP.	MAX.	Unit
Supply Voltage		-----	11.0	12	13.0	Vdc
Absolute Max.Rating		-----		12		Vdc
Supply current +12V	IDD1	w/o LCD & inverter,		10		W
Supply current (power save)	IDDPS1	w/o LCD & inverter,		0.9		W
Video input signal(RGB)	V _i	-----	0.5	0.7	1.0	Vp-p
Output Signal Voltage (3.3V Logic)	V _{out}	High Level	0.7 vdd	3.3		Vdc
		Low Level	-----	0.1	0.2 vdd	Vdc
Data Shift clk Frequency	CP		60	76	82	Mhz
Vertical Frequency					94	khz
Frame Frequency	FLM/Vsync		57	60	63	hz
Sync Level		H sync V sync	4.5	5.0	5.5	Vp-p

6-2. Environmental & Reliability Specification

Operating Conditions	Temperature	0 ~ 50°C
	Humidity	10% ~ 90%, non-condensing
	Altitude	Max. 3,000m
Transportation Conditions	Temperature	-25 ~ 60°C
	Humidity	10% ~ 90%, non-condensing
	Altitude	Max. 15,000m
Storage Conditions	Temperature	-25 ~ 60°C
	Humidity	10% ~ 90%, non-condensing
	Altitude	Max. 3,000m
Reliability Specifications	MTBF	More than 50,000 hours at 90% confidence level, excluding LCD panel.
	Reliability	General Specification of reliability test

7. Supported LCD Panels

This Controller Board supports most LVDS panels on the market.

No	Name	Resolution	Size	Interface	Power	Manufacturer
1	LTM170EU-L31		17.0Inch	2CH,LVDS	5V	Samsung
2	LTM190ET-01		19.0Inch	2CH,LVDS	5V	Samsung
3	M190PW01-V2		19.0Inch	2CH,LVDS	5V	AUO
4	LTM170ET-01		17.0Inch	2CH,LVDS	5V	Samsung
5	LM190E8-TLL2		19.0Inch	2CH,LVDS	5V	LG Philips
6	LM190E8-TLA1		19.0Inch	2CH,LVDS	5V	LG Philips
7	M190EN04-V2		19.0Inch	2CH,LVDS	5V	AUO
8	M185WX01-VD		18.5Inch	1CH,LVDS	5V	AUO
9						
10						
11						
12						
13						
14						
15						
16						
17						
18						
19						
20						
21						
22						
23						
24						
25						

8. OSD(On Screen Display)

8-1. OSD KeyLayout

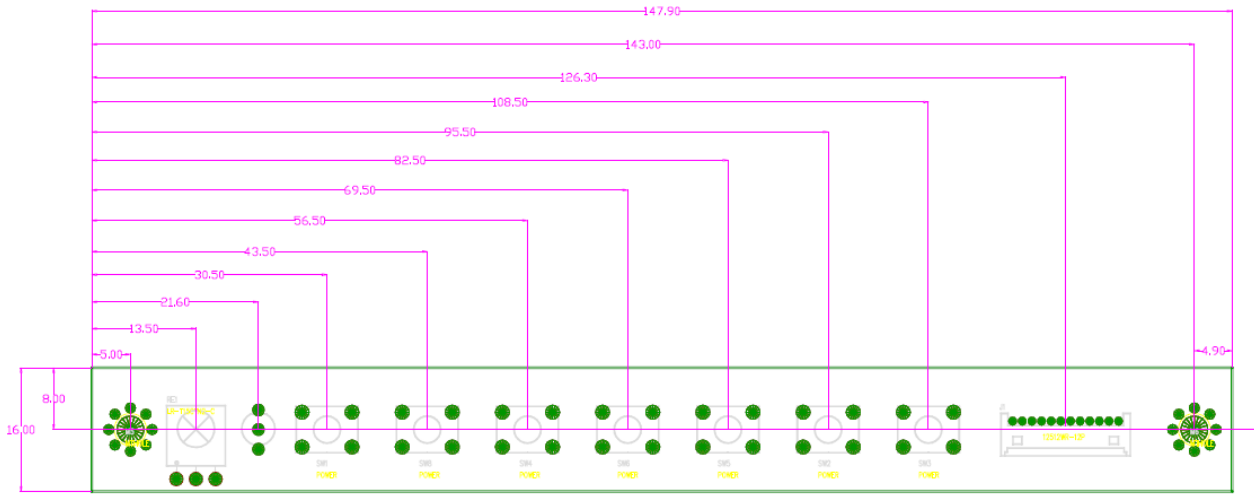

8-2. OSD Key Function

Key name	Key Function
MENU	Open OSD menu window.
MODE/SEL	Select the item value and the input source.
RIGHT	Navigate to right menu.
LEFT	Navigate to left menu.
UP/AUTO	Navigate to up menu, "Auto Adjust" in RGB input only.
DOWN	Navigate to down menu.
POWER	Power on/off.

1. Press the MENU button to access the Main menu.
2. Use the ◀ and ▶ arrow buttons to highlight a selection.
3. Press the ▲ and ▼ button to select an item.
- 4 Use the ◀ and ▶ arrow buttons to adjust the setting on selected item.

8-3. INPUT Select



Input can be set to AV1, AV2, S-VIDEO, HDMI and PC mode.

1. Press the SOURCE button and then ▲/▼ Button to move the source
2. Press the ▶ button to select the source.
3. Press the MENU/EXIT Button to exit the INPUT menu.

8-4.1. PC Main Menu

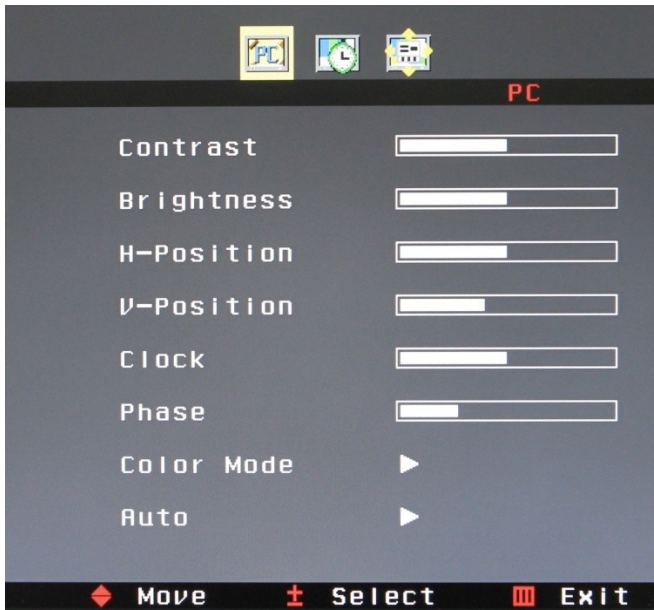

1. Press the MENU/EXIT Button and then ◀/▶ Button to select the FUNCTION menu.
2. Press the ▲or▼ Button and then button to select the Button to select the adjustment item you need.
3. Press the ◀or▶ Button to active the item.
4. Press the MENU/EXIT button to move to the previous menu.

8-4.2. PC Functions MENU

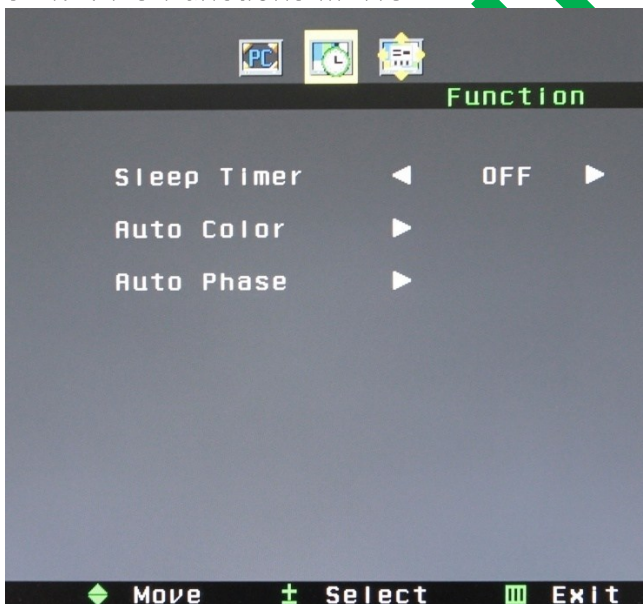

1. Press the MENU/EXIT Button and then ◀/▶ Button to select the PICTURE menu.
2. Press the ▲or▼ Button and then button to select the Button to select the adjustment item you need.
3. Press the ◀or▶ Button to active the item.
4. Press the MENU/EXIT button to move to the previous menu.

8-4.3. PC OSD MENU

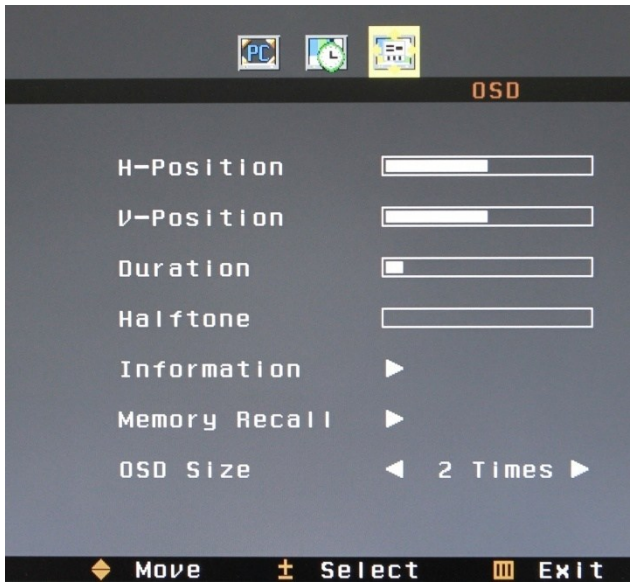

1. Press the MENU/EXIT Button and then ◀/▶ Button to select the OSD menu.
2. Press the ▲or▼ Button and then button to select the Button to select the adjustment item you need.
3. Press the ◀or▶ Button to active the item.
4. Press the MENU/EXIT button to move to the previous menu

8-5.VIDEO PICTURE MENU



1. Press the MENU/EXIT Button and then ◀/▶ Button to select the PICTURE menu.
2. Press the ▲or▼ Button and then button to select the Button to select the adjustment item you need.
3. Press the ◀or▶ Button to active the item.
4. Press the MENU/EXIT button to move to the previous menu.

8-6. HOT KEY Function Definition

- PC Mode

OSD KEY	Function
POWER	POWER ON/OFF
MENU	OSD ON/OFF, Exit
MODE	Mode Change
RIGHT	Volume down
LEFT	Volume up
AUTO	AutoAdjust

- Video Mode

OSD KEY	Function
POWER	POWER ON/OFF
MENU	OSD ON/OFF, Exit
MODE	Mode Change
RIGHT	Volume down
LEFT	Volume up

EX) Volume_Hotkey

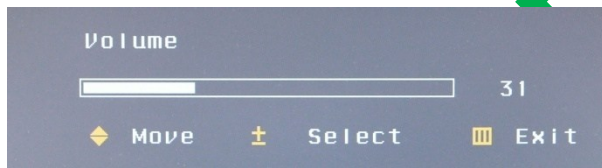

EX) AutoAdjust_Hotkey

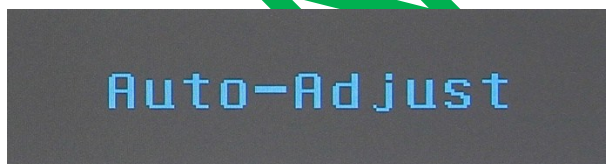

8-7. IR-Remote controller Operations

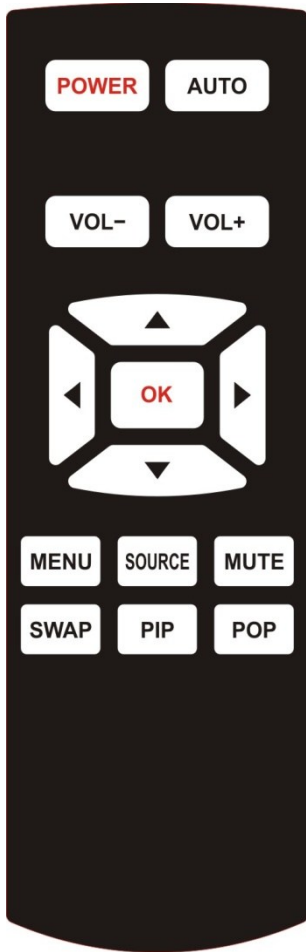

OSD Key	Description
POWER	Power On / Off.
AUTO	Excute Auto-Adjustment automatically optimizing the displayed image.
VOL -	Decrease the volume
VOL +	Increase the volume.
OK	Select the item.
▲	Navigate to next menu on Sub Menu.
▼	Navigate to previous menu on Sub Menu.
◀	Navigate to previous menu on Top Menu. Decreases Gauge Value of Sub Menu
▶	Navigate to next menu on Top Menu. Increases Gauge Value of Sub Menu.
MENU	OSD ON/OFF, Exit
SOURCE	Select the input source.
MUTE	Sound On/Off
SWAP	Swap each other input source on WindowLayout.(Option)
PIP	Hot key to enable PIP Window Layout.(Option)
POP	Hot key to enable POP Window Layout.(Option)

9. INTERFACE DEFINITION

9-1. DC Power IN – (J2)

Pin NO.	SYMBOL	DESCRIPTION
1	12V	DC Power 12V
2	GND	Ground
3	GND	Ground

9-2. DC Sub Input Connector – (CN5)

NO.	SYMBOL	DESCRIPTION
1	12V	DC Power 12V
2	12V	DC Power 12V
3	GND	Ground
4	GND	Ground

9-3. DEBUG Port – (CN8)

NO.	SYMBOL	DESCRIPTION
1	SDA	SDA
2	SCL	SCL
3	GND	Ground
4	N.C	N.C

9-4. Touch Power Output – (CN4)

NO.	SYMBOL	DESCRIPTION									
1	GND	Ground									
2	T_PW	Touch Power Output(+5V/+12V)									
		<table border="1"> <thead> <tr> <th>Power</th> <th>L7</th> <th>L12</th> </tr> </thead> <tbody> <tr> <td>+5 V</td> <td>○(Connecting)</td> <td>N.C</td> </tr> <tr> <td>+12 V</td> <td>N.C</td> <td>○(Connecting)</td> </tr> </tbody> </table>	Power	L7	L12	+5 V	○(Connecting)	N.C	+12 V	N.C	○(Connecting)
		Power	L7	L12							
+5 V	○(Connecting)	N.C									
+12 V	N.C	○(Connecting)									
Ground											
3	GND	Ground									

9-5. PC-RGB IN – (J5)

NO.	SYMBOL	DESCRIPTION
1	RED	Red Video Signal
2	GREEN	Green Video Signal
3	BLUE	Blue Video Signal
4	N.C	Not Connector
5	GND	Shield Ground
6	R-GND	Red Video Signal Ground
7	G-GND	Green Video Signal Ground
8	B-GND	Blue Video Signal Ground
9	VGA 5V	VGA 5V Video Power
10	VGA-DET	VGA Cable Detect
11	N.C	Not Connector
12	DDC-SDA	VGA DDC SDA Data
13	H-SYNC	H Sync Data
14	V-SYNC	V Sync Data
15	DDC-SCL	VGA DDC SCL Data

9-6. HDMI IN-(J3)

NO.	SYMBOL	DESCRIPTION
1	DATA 2+	Data Channel 2 +
2	GND	Ground
3	DATA 2-	Data Channel 2 -
4	DATA 1+	Data Channel 1 +
5	GND	Ground
6	DATA 1-	Data Channel 1 -
7	DATA 0+	Data Channel 0 +
8	GND	Ground
9	DATA 0-	Data Channel 0 -
10	CLK+	Clock Channel +
11	GND	Ground
12	CLK-	Clock Channel -
13	N.C	Not Connector
14	N.C	Not Connector
15	DDC2-SCL	HDMI DDC SCL Data
16	DDC2-SDA	HDMI DDC SDA Data
17	GND	Ground
18	+5V	HDMI 5V Video Power
19	HDMI-DET	HDMI Cable Detect
20	GND	Ground
21	GND	Ground
22	GND	Ground
23	GND	Ground

9-7. CVBS - BNC IN - (J7)

NO.	SYMBOL	DESCRIPTION
1	CVBS	CVBS Video In for BNC
2	GND	Ground

9-8. CVBS - BNC OUT - (J12)

NO.	SYMBOL	DESCRIPTION
1	CVBS	CVBS Video Output for BNC
2	GND	Ground

9-9. CVBS - RCA IN - (J8)

NO.	SYMBOL	DESCRIPTION
1	GND	Ground
2	CVBS	CVBS Video In for RCA
3	N.C	N.C

9-10. CVBS - RCA IN - (J11)

NO.	SYMBOL	DESCRIPTION
1	GND	Ground
2	CVBS	RCA CVBS Video Out for RCA
3	N.C	N.C

9-11.Video Audio IN (Left / Right) – (J9,J10)

NO.	SYMBOL	DESCRIPTION
1	GND	Ground
2	AUDIO-L/ AUDIO-R	Audio Left Input Audio Right Input
3	N.C	N.C

9-12. Audio IN –(J6)

NO.	SYMBOL	DESCRIPTION
1	GND	Ground
2	GND	Ground
3	AUDIO-R	Audio Right Input
4	GND	Ground
5	AUDIO-L	Audio Left Input

9-13.SPEAKERConnector – (CN3)

NO.	SYMBOL	DESCRIPTION
1	SPK-L+	Audio + Left Channel Out
2	SPK-L-	Audio - Left Channel Out
3	SPK-R+	Audio + Right Channel Out
4	SPK-R-	Audio - Right Channel Out

9-14.OSD Interface – (J4)

NO.	SYMBOL	DESCRIPTION
1	POWER	Power Key
2	MENU	Menu Key
3	MODE/SEL	Mode & Select Key
4	LEFT	Left Key
5	RIGHT	Right Key
6	DOWN	Down Key(Vol -)
7	UP/AUTO	Up Key(Vol +)
8	GND	Ground
9	LED_G	LED Green Indicator
10	LED_R	LED Red Indicator
11	VCC	+5V
12	IR_SYNC	IR Signal

9-15. Inverter Connector – (CN2)

NO.	SYMBOL	DESCRIPTION
1	12V	+12V DC Power Supply
2	12V	+12V DC Power Supply
3	GND	Ground
4	GND	Ground
5	INV_ON	Back-Light ON/OFF Control
6	BRIGHT_VBRI	Brightness Adjustment

9-16.LVDS PANEL Connector – (CN9)

NO.	SYMBOL	DESCRIPTION
1	VPENL	Power for Panel
2	VPENL	
3	VPENL	
4	N.C	NC
5	N.C	NC
6	N.C	NC
7	GND	Ground
8	RXE3+	LVDS EVEN 3+ Signal
9	RXE3-	LVDS EVEN 3- Signal
10	RXOC+	LVDS ODD Clock Signal
11	RXOC-	LVDS ODD Clock Signal
12	RXE2+	LVDS EVEN 2+ Signal
13	RXE2-	LVDS EVEN 2- Signal
14	GND	Ground
15	RXE1+	LVDS EVEN 1+ Signal
16	RXE1-	LVDS EVEN 1- Signal
17	GND	Ground
18	RXE0+	LVDS EVEN 0+ Signal
19	RXE0-	LVDS EVEN 0- Signal
20	RXO3+	LVDS ODD 3+ Signal
21	RXO3-	LVDS ODD 3- Signal
22	RXOC+	LVDS ODD Clock+ Signal
23	RXOC-	LVDS ODD Clock- Signal
24	GND	Ground
25	RXO2+	LVDS ODD 2+ Signal
26	RXO2-	LVDS ODD 2- Signal
27	RXO1+	LVDS ODD 1+ Signal
28	RXO1-	LVDS ODD 1- Signal
29	RXO0+	LVDS ODD 0+ Signal
30	RXO0-	LVDS ODD 0- Signal

● Panel Power Select

VPENL	L8	L9	L10
+ 3.3V	N.C	○(Connecting)	N.C
+ 5.0V	○(Connecting)	N.C	N.C
+ 12V	N.C	N.C	○(Connecting)

10. APPLICABLE GRAPHIC MODE

The microprocessor measures the H-sync, V-sync and V-sync/H-sync polarity for RGB inputs, and uses this timing information to control all of the display operation to get the proper image on a screen.

This board can detect all VESA standard and MAC Graphic modes shown on the table below and provide more clear and stable image on a screen.

10-1. RGB Input format

Spec. Mode	Pixel Freq. MHz	Horizontal Timing				Vertical Timing			
		Polar	Freq. KHz	Total Pixel	Active Pixel	Polar	Freq. Hz	Total Line	Active Line
640x350 @70Hz VESA	25.144	P	31.430	800	640	N	70.000	449	350
720x400 @70Hz VESA	28.287	N	31.430	900	720	P	70.000	449	400
640x480 @60Hz MAC	25.175	N	31.469	800	640	N	59.940	525	480
640x480 @60Hz VESA	25.175	N	31.469	800	640	N	59.940	525	480
640x480 @67Hz MAC	30.240	N	35.000	864	640	N	66.667	525	480
640x480 @72Hz VESA	31.500	N	37.861	832	640	N	72.809	520	480
640x480 @75Hz VESA	31.500	N	37.500	840	640	N	75.000	500	480
832x624 @75Hz MAC	57.284	N	49.726	1152	832	N	74.551	667	624
800x600 @56Hz VESA	36.000	P	35.156	1024	800	P	56.250	625	600
800x600 @60Hz VESA	40.000	P	37.879	1056	800	P	60.317	628	600
800x600 @72Hz VESA	50.000	P	48.077	1040	800	P	72.188	666	600
800x600 @75Hz VESA	49.500	P	46.875	1056	800	P	75.000	625	600
1024x768 @60Hz VESA	65.000	N	48.363	1344	1024	N	60.005	806	768
1024x768 @60Hz MAC	64.000	N	48.780	1312	1024	N	60.001	813	768
1024x768 @70Hz VESA	75.000	N	56.476	1328	1024	N	70.070	806	768
1024x768 @75Hz MAC	80.000	N	60.241	1328	1024	N	74.927	804	768
1024x768 @75Hz VESA	78.750	P	60.023	1312	1024	P	75.030	800	768
1280x1024 @60Hz VESA	108.000	P	63.981	1688	1280	P	60.020	1066	1024
1280x1024 @70Hz VESA	125.000	N	74.405	1680	1280	N	69.995	1063	1024
1280x1024 @75Hz VESA	135.000	P	79.976	1688	1280	P	75.025	1066	1024
1152x864 @75Hz VESA	108.000	P	67.500	1600	1152	P	75.000	900	864
1152x900 @76Hz VESA	105.561	N	71.713	1472	1152	N	76.047	943	900
1152x870 @75Hz MAC	100.000	N	68.681	1456	1152	N	75.062	915	870
1680*1050 @60Hz VESA	146.25	N	65.290	2278	1680	P	59.954	1089	1050

10-2. HDMI Input format

Mode	Spec. Pixel Freq. MHz	Horizontal Timing				Vertical Timing			
		Sync Polar	Freq. KHz	Total Pixel	Active Pixel	Sync Polar	Freq. Hz	Total Line	Active Line
480i	13.500		15.734				29.970		
480p	27.000		27.000				59.940		
576i	13.5000		15.625				50.000		
576p	27.000		31.250				50.000		
720p	74.250		45.000				60.000		
720p	74.176		45.000				59.940		
720p	74.250		37.500				50.000		
640x400 @60Hz	25.175	N	31.469	900	640	P	59.940	449	400
640x480 @60Hz	25.175	N	31.469	800	640	N	59.940	525	480
640x480 @60Hz VESA	25.200	N	31.500	800	640	N	60.000	525	480
640x480 @72Hz VESA	31.500	N	37.861	832	640	N	72.809	520	480
640x480 @75Hz VESA	31.500	N	37.500	840	640	N	75.000	500	480
832x624 @75Hz MAC	57.284	N	49.726	1152	832	N	74.551	667	624
800x600 @56Hz VESA	36.000	P	35.156	1024	800	P	56.250	625	600
800x600 @60Hz VESA	40.000	P	37.879	1056	800	P	60.317	628	600
800x600 @72Hz VESA	50.000	P	48.077	1040	800	P	72.188	666	600
800x600 @75Hz VESA	49.500	P	46.875	1056	800	P	75.000	625	600
1024x768 @60Hz VESA	65.000	N	48.363	1344	1024	N	60.005	806	768
1024x768 @60Hz MAC	64.000	N	48.780	1312	1024	N	60.001	813	768
1024x768 @70Hz VESA	75.000	N	56.476	1328	1024	N	70.070	806	768
1024x768 @75Hz MAC	80.000	N	60.241	1328	1024	N	74.927	804	768
1024x768 @75Hz VESA	78.750	P	60.023	1312	1024	P	75.030	800	768
1280x1024 @60Hz VESA	108.000	P	63.981	1688	1280	P	60.020	1066	1024
1280x1024 @70Hz VESA	125.000	N	74.405	1680	1280	N	69.995	1063	1024
1280x1024 @75Hz VESA	135.000	P	79.976	1688	1280	P	75.025	1066	1024